

Chapter 7

BUILDING♣

- Art. 7-1. Administration, §§ 7-1-1 – 7-1-6**
- Art. 7-2. Building Codes, §§ 7-2-1 – 7-2-6**
- Art. 7-3. Permits Required, §§ 7-3-1 – 7-3-7**
- Art. 7-4. Certificates, §§ 7-4-1 – 7-4-2**
- Art. 7-5. Building Permit Fees, §§ 7-5-1 – 7-5-6**
- Art. 7-6. Numbering of Buildings; Naming of Streets, §§ 7-6-1 – 7-6-10**
- Art. 7-7. Development Fees, §§ 7-7-1 – 7-7-9**
- Art. 7-8. Records and Penalty, §§ 7-8-1 – 7-8-3**

ARTICLE 7-1. ADMINISTRATION♣

Sec. 7-1-1. Administration.

The planning and zoning department shall administer this chapter. The executive official in charge thereof, or his/her designee, shall be known as the building official.

(Ord. No. 399, §§ 1-3, 7-16-96; Ord. No. 2004-23, §§ 1-2, 11-16-04; Ord. No. 2008-15, § 1, 12-16-08, and readopted §§ 1-2, 5-19-09)

Sec. 7-1-2. Building official duties.

It shall be the duty of the building official to administer this chapter. All city law enforcement officials and agencies shall, whenever requested by the building official, enforce this chapter to the extent that they are lawfully authorized to do so.

(Ord. No. 399, §§ 1-3, 7-16-96; Ord. No. 2004-23, §§ 1-2, 11-16-04)

♣Editor's note—Ord. No. 2004-23, §§ 1 – 2, adopted Nov. 16, 2004, repealed and adopted, respectively, Chapter 7 in its entirety. Previously, Ord. No. 370, §§ 1 – 3, adopted Feb. 1, 1994, repealed Arts. 7-1 – 7-14 and amended Arts. 7-1 – 7-14. Said articles pertained to buildings and derived from Ord. No. 77, §§ 1 – 3, adopted Dec. 21, 1977; Ord. No. 94-A, § 1, adopted April 25, 1979; Ord. No. 97, § 1, adopted July 25, 1979; Ord. No. 153, § 1, adopted May 5, 1982; Ord. No. 159, § 1, adopted July 21, 1982; Ord. No. 168, §§ 1 – 7, adopted Feb. 23, 1983; Ord. No. 233, §§ 1 – 11, adopted June 4, 1985; Ord. No. 300, adopted Feb. 2, 1989 and Ord. No. 321, §§ 1 – 9, adopted Aug. 21, 1990.

Editor's note—Ord. No. 2008-15, § 1, adopted Dec. 16, 2008, adopted Chapter 7 in its entirety. Ord. No. 2008-15, §§ 1-2, adopted May 19, 2009, repealed and adopted, respectively, Chapter 7 in its entirety.

Cross references—Health and sanitation, Ch. 9; offenses, Ch. 10; sewers, Ch. 11; subdivision, Ch. 12; water, Ch. 14; planning and zoning, Ch. 15; flood damage prevention, Ch. 19.

Sec. 7-1-3. Administrative provisions.

Part I of the international building code, as adopted below, shall be used as the administrative rules for administering this chapter, except as otherwise provided in the City Code.

(Ord. No. 399, §§ 1-3, 7-16-96; Ord. No. 523, § 2, 1-7-03; Ord. No. 2004-23, §§ 1-2, 11-16-04)

Sec. 7-1-4. Rules and regulations; adoption; effect.

The building official may adopt rules and regulations, subject to the approval of the city council in the interest of public safety, health and general welfare, to implement the provisions of this chapter and to secure the intent thereof; but no such rules shall have the effect of waiving technical provisions specifically provided in the international building code or of violating accepted engineering practice involving public safety.

(Ord. No. 399, §§ 1-3, 7-16-96; Ord. No. 523, § 5, 1-7-03; Ord. No. 2004-23, §§ 1-2, 11-16-04)

Sec. 7-1-5. Board of appeals defined.

Whenever the terms "board of appeals," "adjustment board" or "board" are used in the international building codes, they shall mean the board of adjustment as created and the duties of which are described in this Code.

(Ord. No. 399, §§ 1-3, 7-16-96; Ord. No. 523, § 3, 1-7-03; Ord. No. 2004-23, §§ 1-2, 11-16-04)

Sec. 7-1-6. Appeals to board of adjustment.

The final decision of the building official may be appealed to the board of adjustment in the same manner as provided for appeals of the zoning administrator in section 15-1-5(B) of this Code. Appeals to the board of adjustment shall be a necessary administrative procedure and condition precedent to the filing of any legal action regarding any decision of the building official.

(Ord. No. 2004-23, §§ 1-2, 11-16-04)

ARTICLE 7-2. BUILDING CODES

Sec. 7-2-1. Creation.

The following building code is created in order to provide minimum standards safeguarding life or limb, health, property and public welfare. This is accomplished by regulating and controlling the design, construction, quality of materials, use and occupancy, location and maintenance of all buildings and structures within the city.

(Ord. No. 399, §§ 1-3, 7-16-96; Ord. No. 2004-23, §§ 1-2, 11-16-04)

Sec. 7-2-2. Title.

This code shall be known as the “Building Codes of the City of Show Low.”

(Ord. No. 399, §§ 1-3, 7-16-96; Ord. No. 2004-23, §§ 1-2, 11-16-04)

Sec. 7-2-3. Rules and definitions.

The term "international building codes" as used herein shall mean the codes referred to in section 7-2-4 of this article. The terms used in this article shall be defined as provided in the codes adopted in this chapter, except as herein otherwise provided. Whenever the terms "other code" or "other codes" are used in the international building codes, they shall mean other code or codes adopted by either the City of Show Low or the State of Arizona. If there is a conflict between such other code or codes and this article, the more restrictive shall prevail. Reference to chapters, articles, sections and subsections or paragraphs and to tables thereof are to the international building codes.

(Ord. No. 399, §§ 1-3, 7-16-96; Ord. No. 507, 1-2-02; Ord. No. 523, § 1, 1-7-03; Ord. No. 2004-23, §§ 1-2, 11-16-04)

Sec. 7-2-4. Building codes.

The following described documents containing the following described codes, as the same now exists or may hereafter be amended, or as specifically amended herein, are hereby adopted by reference, as if fully set out herein, and are collectively referred to as the “Building Codes of the City of Show Low, Arizona.”

The 2006 IBC codes referred to herein are hereby adopted. Future editions of these codes may be adopted from time to time by the city council by resolution, and for the next twelve (12) months, either the most recent or the previous edition may be used for building design requirements. The provisions of both codes may not be intermingled in the design of a building. Twelve (12) months after the date of publication and adoption

of the latest edition of a code, only that code may be used as the design requirements for any building to be constructed in the City of Show Low.

Copies of the international building codes are on file at the Show Low City Hall, Show Low, Arizona. They may be purchased from the Code Council, 5360 South Workman Mill Road, Whittier, California.

(A) International Building Code, together with its appendices and supplements, if any, published by the Code Council.

(1) Standards and specifications set forth in Title 41, Chapter 9, Article 8, Arizona Revised Statutes (Arizonans with Disabilities Act), and its implementing rules, including "*Americans with Disabilities Act Accessibility Guidelines for Buildings and Facilities*" declared a public record by Resolution No. 772, as applying to public entities, are hereby adopted and incorporated as an amendment to the international building code adopted in section 7-1-4 and made part thereof as fully set forth therein. Such standards and specifications shall apply to new construction and alterations and are not required in buildings or portions of existing buildings that do not meet the standards and specifications.

(2) Standards and specifications set forth in Title 41, Chapter 9, Article 8, Arizona Revised Statutes (Arizonans with Disabilities Act), and its implementing rules, including "*Americans with Disabilities Act Accessibility Guidelines for Buildings and Facilities*" declared a public record by Resolution No. 772, as applying to public accommodations and commercial facilities, are hereby adopted and incorporated as an amendment to the international building code adopted in section 7-1-4 and made part thereof as though fully set forth therein. Such standards and specifications shall apply to new construction and alterations commenced after September 3, 1996.

(3) Addenda and additions to the building code. The following addenda and additions to the previously described codes as apply to Show Low, Arizona:

Minimum footings:

One story frame construction

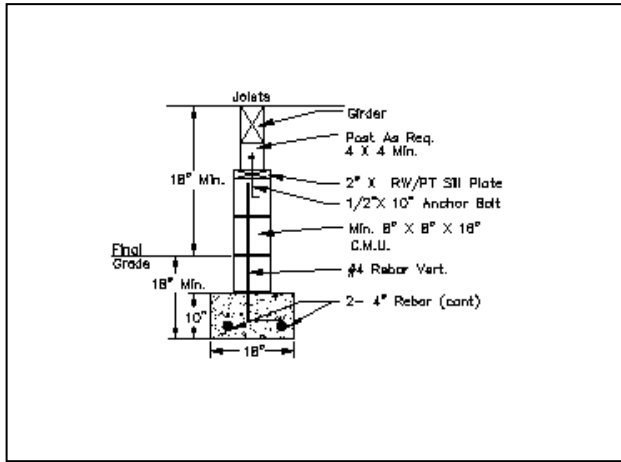

Figure 1. Stem walls and wood floors

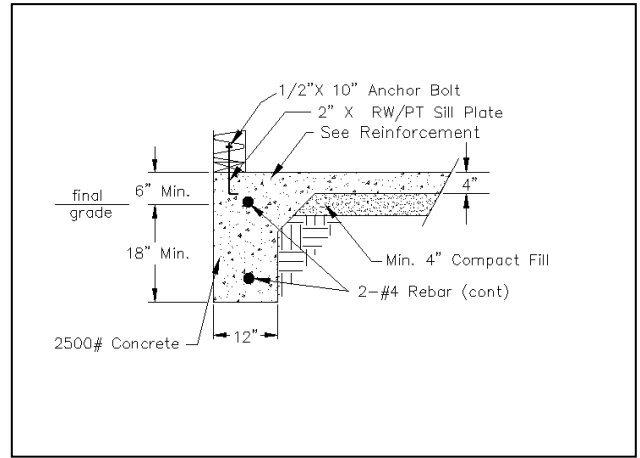

Figure 2. Monolithic

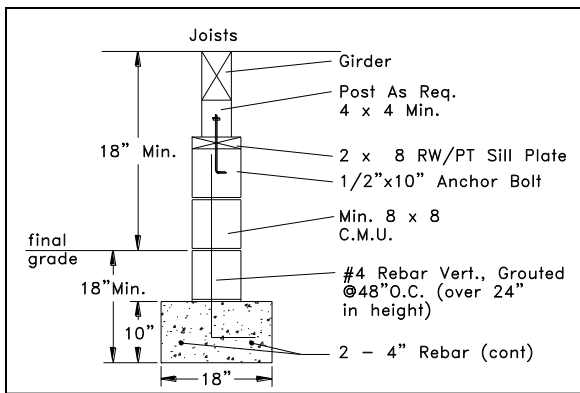

Figure 3.

Figures 3 and 4. Pier detail for frame porches and decks only

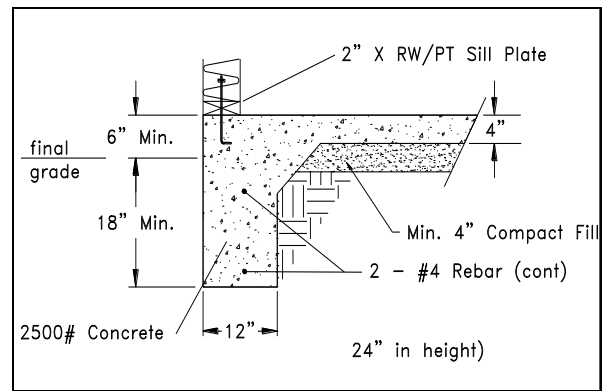

Figure 4.

Two story masonry construction

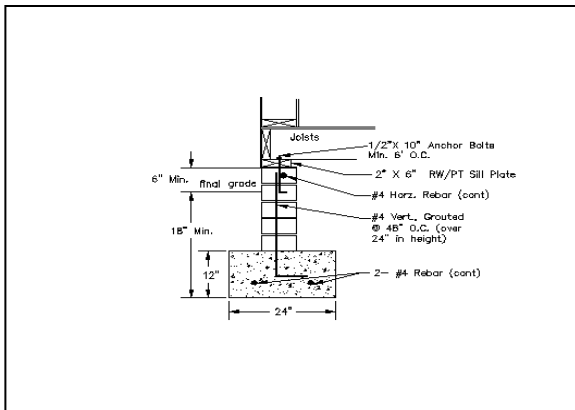

Figure 5. Piers

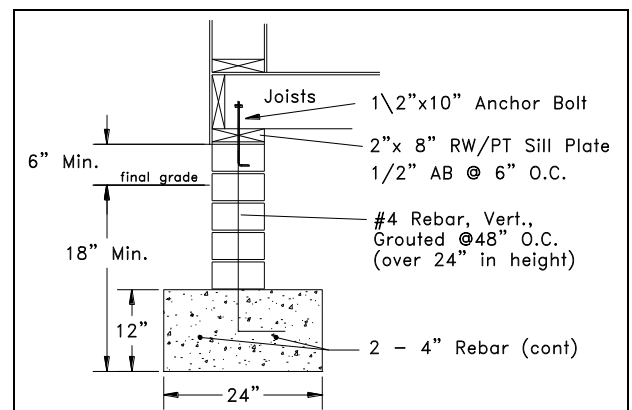

Figure 6. Stem walls and wood floors

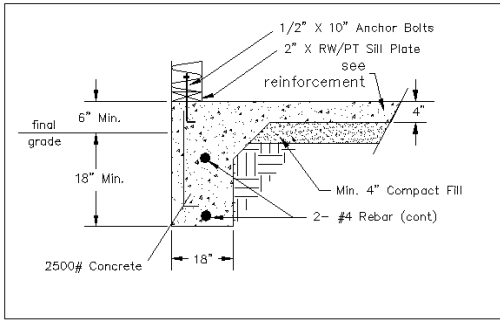

Figure 7. Monolithic

Minimum slabs:

One story frame construction

All concrete slabs that are to be under a roof must be reinforced with fiber mesh, woven wire mesh, or minimum three-eighths (3/8) inch rebar spaced no more than thirty (30) inches O.C. each way.

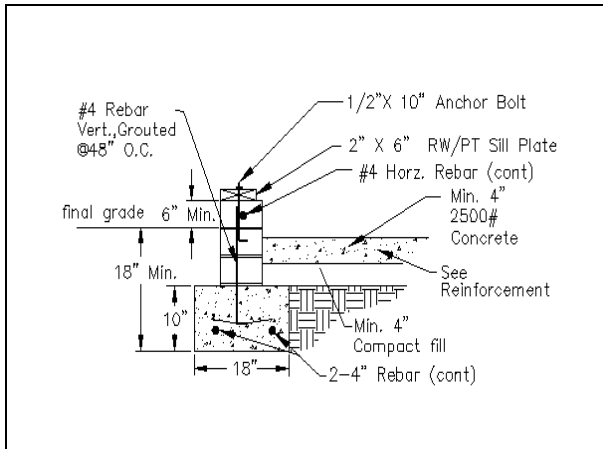

Figure 8. Slab construction stem wall.

Two story masonry construction

All concrete slabs that are to be under a roof must be reinforced with fiber mesh, woven wire mesh, or minimum three-eighths (3/8) inch rebar spaced no more than thirty (30) inches O.C. each way.

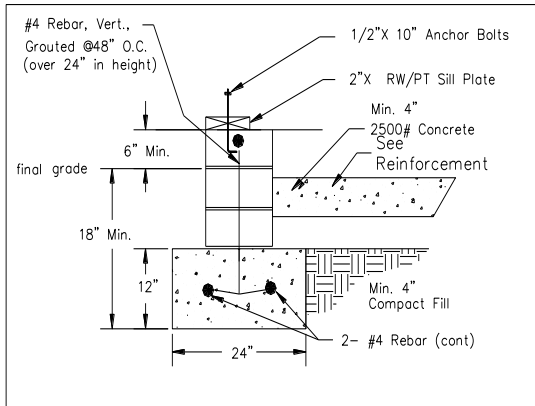

Figure 9. Slab construction stem wall

Foundation sills: Foundation Redwood or P.T. (Note: P.T. – Pressure treatment to meet sec. 1403.6.) Sills shall be 2" x 6" minimum.

Piers: Redwood or P.T. fir sills shall cover the full width of the pier or 2" x 6" on 8" block.

Girder, beams and bearing wall header spans: No. 2 and BTR H.F. (laminated 2" nominal allowable in lieu of 4" thickness material).

Roof loads:

Less than 4" - 12" pitch – Snow load 35 lb. PST

4" - 12" pitch and greater – Snow load 30 lb. PST

Engineering calculations and design data may be required for any unusual design or long span roof systems at the discretion of the building official, prior to issuance of a permit.

Electrical: Ground fault circuit interrupters (G.F.C.I.) are required on all temporary service outlets.

- (B) The International Residential Code for One-and Two-Family Dwellings, together with supplements, if any, published by the International Code Council.
- (C) International Fuel Gas Code, together with its supplements, if any, published by the International Code Council.
- (D) Addenda to the International Fuel Gas Code.
 - (1) Section 403.5.2, Copper and brass tubing, is amended to read:

"Copper and brass tubing and similar pipe and fittings made up of copper or brass shall not be approved for use with natural gas fuel systems."
 - (2) Section 403.5.3, Aluminum tubing, is amended to read:

"Aluminum-alloy tubing used for connections to appliances shall not be permitted in the City of Show Low and are to be replaced with approved listed appliance connectors when a permit to install/replace the appliance being served is issued.

Aluminum-alloy tubing shall not be used in exterior locations or underground."
 - (3) Section 406.4.1, Test pressure, is amended to read:

"Test pressure shall be no less than 1.5 times the maximum working pressure not less than 3 pounds of air for a period not less than fifteen minutes using an air test pressure gauge with 1/10 pound increments. Where the test pressure exceeds 125 psig (862 kPa gauge), the test pressure shall not exceed a value that produces a hoop stress in the piping greater than 50 percent of the specified minimum yield strength of the pipe."
 - (4) Section 406.4.2, Test duration, is amended to read:

"Test duration shall be not less than ½ hour for each 500 cubic feet (14 m³) of pipe volume or fraction thereof. When testing a system having a volume less than 10 cubic feet (0.28 m³) or a system in a single-family or multi-family dwelling, the test duration shall be not less than 15 minutes. The duration of the test shall not be required to exceed 24 hours."
- (E) International Mechanical Code, together with its supplements, if any, published by the International Code Council.
- (F) International Plumbing Code, together with its supplements, if any, published by the Code Council.

- (G) National Electrical Code, together with its supplements, if any, published by the National Fire Protection Association.
- (H) International Fire Code, together with its supplements, appendices, if any, published by the International Code Council.
- (I) Addenda to the International Fire Code.

Appendix A of the International Fire Code provides for a board of appeals. The board of adjustment shall serve as the board of appeals.

- (J) International Existing Building Code, together with its supplements, and appendices, if any, published by the International Code Council.
- (K) Addenda to the International Existing Building Code.
 - (1) For purposes of Section 112 the board of adjustment shall serve as the board of appeals.
 - (2) For purposes of Section 1201.2 the applicable date shall be May 7, 1976.

(Ord. No. 458, 11-2-99; Ord. No. 507, 1-2-02; Ord. No. 523, § 1, 1-7-03; Ord. No. 2004-04, § 1, 4-20-04; Ord. No. 2004-07, § 1, 5-19-04; Ord. No. 2004-23, §§ 1-2, 11-16-04; Ord. No. 2005-16, § 1, 6-21-05; Ord. No. 2008-15, § 1, 12-16-08)

Sec. 7-2-5. Mobile/manufactured homes.

- (A) Mobile/manufactured homes proposed for installation shall have affixed thereto a decal certifying that the dwelling unit has been inspected and constructed in accordance with the requirements of the U.S. Department of Housing and Urban Development (HUD) in effect at the date of manufacture wherein such date shall not have been prior to June 15, 1976, or such other succeeding requirements which replace HUD standards.
- (B) As of May 4, 1994, the building official shall not issue a building/location permit for installation of a manufactured home within the City of Show Low unless said manufactured home can be proven to comply with those standards set forth in (A) above. This prohibition shall also apply to any manufactured home unit installation permit sought to be issued for the location of any manufactured home unit within the City of Show Low.
- (C) It shall be the responsibility of permit applicants to demonstrate to the building official that any manufactured home for which an installation/location permit is requested is in compliance with the standards set forth in (A) above.

- (D) Mobile/manufactured homes proposed for installation shall be installed in compliance with the standards prescribed by the Arizona Department of Building and Fire Safety, Office of Manufactured Housing for either:
- (1) Ground level installation;
 - (2) Installation of a fully skirted mobile/manufactured home; or
 - (3) Installation of a unit on a permanent visible foundation.
- (E) The prohibition contained in this section shall not apply to a mobile/manufactured home which must be relocated due to a “change in use.” Any such mobile/manufactured home may be moved from a mobile home park located within the city to another mobile home park located within the city which will permit acceptance of the unit, after issuance of the building/location permit described in this section.

As used in this section, “change in use” means a change in the use of land from the rental of mobile home spaces in a mobile home park to some other use.

(Ord. No. 399, §§ 1-3, 7-16-96; Ord. No. 413, § 1, 5-21-97; Ord. No. 2004-23, §§ 1-2, 11-16-04)

Sec. 7-2-6. Responsibility of building official to review codes.

The International Code Council and other publishers identified in section 7-2-4 of this chapter, issue each edition of the international building codes periodically which is maintained by annual supplements. In order that this chapter maintains its continuity, it shall be the responsibility of the building official to ensure that all such supplements and amendments to the codes are properly implemented. All supplements and amendments shall be included in this chapter as soon as such supplements and amendments are received by the City of Show Low and are made available for inspection at the city offices.

(Ord. No. 399, §§ 1-3, 7-16-96; Ord. No. 523, § 3, 1-7-03; Ord. No. 2004-23, §§ 1-2, 11-16-04)

ARTICLE 7-3. PERMITS

Sec. 7-3-1. Permit required.

Permits shall be required as provided in the adopted building codes of the City of Show Low and this chapter 7, except as otherwise set forth below.

(Ord. No. 370, §§ 1-3, 2-1-94; Ord. No. 2004-23, §§ 1-2, 11-16-04)

Sec. 7-3-2. Application.

Permits shall be issued upon approval of submitted plans and specifications and presentation of an approved sanitary system permit where required. Permit applications shall normally be accepted at the City Hall, Show Low, Arizona, 8:00 a.m. to 5:00 p.m., Monday through Friday. Hours and days are subject to change.

(Ord. No. 399, §§ 1-3, 7-16-96; Ord. No. 2004-23, §§ 1-2, 11-16-04)

Sec. 7-3-3. Restriction.

No permit shall be issued to any person or persons who propose to contract the doing of any work regulated by this code, unless the person requesting the permit is the holder of a valid, unexpired and unrevoked contractor's license issued by the State of Arizona or the bona fide owner of the premises upon which the work regulated by this code is to be done. The property owner or contractor is responsible to comply with state contracting laws.

(Ord. No. 399, §§ 1-3, 7-16-96; Ord. No. 2004-23, §§ 1-2, 11-16-04)

Sec. 7-3-4. Building permits not required.

The following shall be exempt from the requirements of issuance of a permit and collection of fees:

- (A) All exemptions listed in applicable provisions of the current code.
- (B) One (1) story tool and storage sheds, greenhouses, barns and other accessory buildings not used for human occupancy, up to one hundred forty-four (144) square feet.
- (C) Repairs which involve only the replacement of existing component parts with similar materials for the purpose of maintenance. Repairs exempt from permit requirements shall not include any additions, change of design or modification in construction, exit facilities or permanent fixtures or equipment. Specifically exempt from permit requirements without limitation are:
 - (1) Painting and decorating;

- (2) Installation of floor coverings and drapes;
- (3) Cabinetry and finished carpentry work;
- (4) Storm doors and windows, including arcadia doors.

(Ord. No. 399, §§ 1-3, 7-16-96; Ord. No. 523, § 6, 1-7-03; Ord. No. 2004-23, §§ 1-2, 11-16-04; Ord. No. 2008-15, § 1, 12-16-08)

Sec. 7-3-5. Compliance regarding issuance of permits and licenses.

All department officials and public employees of the City of Show Low, vested with the duty or authority to issue permits or licenses, shall comply with the provisions of this chapter and shall issue no permit or license for any use, building or purpose in conflict with the provisions of this chapter. Any permit or license so issued in conflict with the provisions of this chapter, shall be null and void and of no effect whatsoever. Upon the issuance of a building permit the reporting requirements of A.R.S. §9-467, as amended from time to time, shall be met.

(Ord. No. 399, §§ 1-3, 7-16-96; Ord. No. 2004-23, §§ 1-2, 11-16-04)

Sec. 7-3-6. Filing of plans.

A pre-application meeting is required for all new commercial construction and substantial commercial remodels or additions.

Every application for a building permit shall be accompanied by:

- (A) Residential: two (2) copies of plans and specifications.
- (B) New commercial: six (6) copies of plans and specifications
- (C) Commercial tenant improvement: four (4) copies of plans and specifications or as otherwise required by building department.

Plans shall include scaled drawings site or plot plans. One (1) copy of such accepted plans shall be returned to the owner when plans are approved by the building official.

(Ord. No. 399, §§ 1-3, 7-16-96; Ord. No. 2004-23, §§ 1-2, 11-16-04; Ord. No. 2008-15, § 1, 12-16-08)

Sec. 7-3-7. Plans and specifications.

With each application for a building permit and also when otherwise required by the building official for enforcement of any provision of this chapter, two (2) sets of specifications and plans shall be submitted. The building official may, where the complexity of the plans clearly warrant (that is any building requiring engineering computations, e.g., public buildings, etc.), require plans and specifications to be prepared and designed by an engineer or architect licensed by the state to practice as such. The building official may further require that plans for new construction indicate existing and finished grade elevations based on city data, with existing and finished drainage flow patterns in areas subject to flooding. One (1) copy of submitted plans shall be returned to the applicant when approved. The applicant shall be responsible for determining which plan review process will be followed. The timelines outlined within each process apply only to city review and do not include the time that comments have been returned to the applicant for required revisions or to the time required for third-party plan review.

- (A) Standard Plan Review. The purpose of the Standard Plan Review is to allow the applicant and city staff to work together to help expedite the plan review and approval process. By selecting this option, the applicant is authorizing the city to provide written and oral comments related to requirements for plan approval. It is understood that multiple comments and/or revisions to plans may be required in order to obtain approvals. As part of this approval process, the city will have all approvals in place within thirty (30) working days from the date of submittal provided all required information has been submitted to and approved by the city. This time period shall not include the time in which the city has returned comments to the applicant and is awaiting corrections or additional information. This time period may be extended through mutual agreement by the city and the applicant.
- (B) Non-Standard Plan Review. The purpose of the Non-Standard Plan Review is to comply with the plan review process as outlined in Title 9, Chapter 7, Article 4, of Arizona Revised Statutes as may be amended from time to time. By selecting this option, the applicant is requiring the city to comply with the review requirements as outlined in the Arizona Revised Statutes. These statutes require the successful completion of two separate review processes prior to approval of a building permit.
 - (1) Administrative Review. The purpose of the Administrative Review is to ensure that all required information is included as part of the permit application and that all submitted information is correct. The timeframe for Administrative Review is twenty (20) working days. This time period shall not include the time in which the city has returned comments to the applicant and is awaiting corrections or additional information. Once the Administrative Review process is complete and the applicant has been given a notice to proceed, the applicant will then submit the required information for Substantive Review.

- (2) **Substantive Review.** The purpose of the Substantive Review is to ensure that all information required for a permit has been submitted and that all required approvals have been obtained. The timeframe for Substantive Review is twenty (20) working days. This time period shall not include the time in which the city has returned comments to the applicant and is awaiting corrections or additional information. Once the Substantive Review process is complete and all approvals have been obtained, the permit shall be issued. If the permit is deemed not complete, the permit application shall be denied and the applicant shall be required to reapply for a building permit.

When the plans are approved, they will be so identified by the placing on each page of a “reviewed” stamp indicating the name of the person approving the plans and the date of approval. This set of plans must be available to the building inspector at the job site at the time of each inspection.

(Ord. No. 399, §§ 1-3, 7-16-96; Ord. No. 2004-23, §§ 1-2, 11-16-04; Ord. No. 2008-15, § 1, 12-16-08; Ord. No. 2011-13, §§ 1-3, 12-6-11, Eff. 1-6-12; Ord. No. 2012-06, §§ 1-3, 11-20-12)

ARTICLE 7-4. CERTIFICATES

Sec. 7-4-1. Certificate of occupancy.

When final inspection indicates a building is in full compliance with the codes, a certificate of occupancy shall be issued. No building may be occupied for any reason or purpose until after a final inspection has been performed and the certificate of occupancy issued. Upon issuance of a certificate of occupancy, the reporting requirements of A.R.S. §9-467, as amended from time to time, shall be met.

Should it become necessary to occupy a building prior to the completion of all the code requirements, a final inspection must be scheduled, and at this time, if the uncompleted items are not a threat to the health and safety of the occupants, a temporary certificate of occupancy may be issued for a specified period of time. By the end of this time period, for continued occupancy of the building, the uncompleted items must have been completed, another final inspection performed and the certificate of occupancy issued, or arrangements have been made for additional time to complete the items stated on the temporary certificate of occupancy.

Certificates of occupancy are not issued for accessory buildings and the foregoing does not apply to these types of buildings.

(Ord. No. 399, §§ 1-3, 7-16-96; Ord. No. 2004-23, §§ 1-2, 11-16-04)

Sec. 7-4-2. Certificate of compliance.

The certificate of compliance is for existing structures. It may be associated with premoving, renovation, use change, addition and existing structure or housing code. A letter of certification (duplicate certification) may be for other than the original issue.

(Ord. No. 399, §§ 1-3, 7-16-96; Ord. No. 2004-23, §§ 1-2, 11-16-04)

ARTICLE 7-5. BUILDING PERMIT FEE SCHEDULE

Sec. 7-5-1. Generally.

The common council of the City of Show Low may from time to time establish and set by resolution the amount of charges for all building permit fees within the jurisdiction of the City of Show Low.

(Ord. No. 399, §§ 1-3, 7-16-96; Ord. No. 523, § 7, 1-7-03; Ord. No. 2004-23, §§ 1-2, 11-16-04; Ord. No. 2016-01, § 1, 1-5-16)

Sec. 7-5-2. Revised plans.

The common council of the City of Show Low may from time to time establish and set by resolution the amount of charges for all plan review fees, including substitution or revised plans, within the jurisdiction of the City of Show Low.

(Ord. No. 399, §§ 1-3, 7-16-96; Ord. No. 523, § 8, 1-7-03; Ord. No. 2004-23, §§ 1-2, 11-16-04; Ord. No. 2008-15, § 1, 12-16-08; Ord. No. 2016-01, § 1, 1-5-16)

Sec. 7-5-3. Fee refunds.

The common council of the City of Show Low may from time to time establish and set by resolution the amount of charges for all transfer, cancellations, and refunds of permits within the jurisdiction of the City of Show Low.

(Ord. No. 399, §§ 1-3, 7-16-96; Ord. No. 2004-23, §§ 1-2, 11-16-04; Ord. No. 2008-15, § 1, 12-16-08; Ord. No. 2016-01, § 1, 1-5-16)

Sec. 7-5-4. Special fees.

The common council of the City of Show Low may from time to time establish and set by resolution the amount of charges for all special permit fees within the jurisdiction of the City of Show Low.

(Ord. No. 399, §§ 1-3, 7-16-96; Ord. No. 523, § 8, 1-7-03; Ord. No. 2004-23, §§ 1-2, 11-16-04; Ord. No. 2008-15, § 1, 12-16-08; Ord. No. 2016-01, § 1, 1-5-16)

Sec. 7-5-5. Location permit fee.

The common council of the City of Show Low may from time to time establish and set by resolution the amount of charges for all location permit fees within the jurisdiction of the City of Show Low.

(Ord. No. 399, §§ 1-3, 7-16-96; Ord. No. 2004-23, §§ 1-2, 11-16-04; Ord. No. 2008-15, § 1, 12-16-08; Ord. No. 2016-01, § 1, 1-5-16)

Sec. 7-5-6. Independent inspections.

The common council of the City of Show Low may from time to time establish and set by resolution the amount of charges for all independent inspections within the jurisdiction of the City of Show Low.

(Ord. No. 2008-15, § 1, 12-16-08; Ord. No. 2016-01, § 1, 1-5-16)

ARTICLE 7-6. NUMBERING OF BUILDINGS; NAMING OF STREETS♣

Sec. 7-6-1. Uniform numbering system established.

There is hereby established a uniform system for numbering buildings fronting on all streets, avenues and public ways in the city and all houses and other buildings shall be numbered in accordance with the provisions of this article.

(Ord. No. 288, § 1, 5-3-88; Ord. No. 2004-23, §§ 1-2, 11-16-04)

♣Editor's **note**—Sections 1 and 2 of Ord. No. 2004-23, adopted Nov. 16, 2004, repealed and adopted, respectively, Chapter 7 in its entirety. Previously, Art. 7-6, *Numbering of Buildings; Naming of Streets*, was included as Art. 7-15, §§ 7-15-1 – 7-15-11 at the discretion of the editor (§§ 1 – 11 of Ord. No. 288, adopted May 3, 1988, did not specifically amend this Code).

Cross references—Subdivision, Ch. 12; planning and zoning, Ch. 15; streets and sidewalks, Ch. 18.

Sec. 7-6-2. Baselines for dividing city.

McNeil Street shall constitute the baseline which will divide the city into northern and southern parts. Hereafter, all streets north of this baseline and running generally in a northerly-southerly direction shall be considered "north" streets, and likewise all streets south of this baseline and running in a generally northerly-southerly direction shall be considered "south" streets. Central Avenue shall be considered the baseline which divides the city into east and west parts. Hereafter, streets east of this baseline and running in a generally easterly-westerly direction shall be considered "east" streets and likewise streets west of and running in a generally easterly-westerly direction shall be considered "west" streets.

- (A) Each building north of McNeil Street and facing a street running in a northerly direction shall carry a number indicating its location north of such base street.
- (B) Each building south of McNeil Street and facing a street running in a southerly direction shall carry a number and address indicating its location south of such base street.
- (C) Each building east of Central Avenue and facing a street running in an easterly direction shall carry a number and address indicating its location east of such base street.
- (D) Each building west of Central Avenue and facing a street running in a westerly direction shall carry a number and address indicating its location west of such base street.
- (E) All buildings on diagonal streets shall be numbered the same as buildings on northerly and southerly streets if the diagonal runs more from the north to south, and the same rule shall apply on easterly and westerly streets if the diagonal runs more from east to west.

(Ord. No. 288, § 2, 5-3-88; Ord. No. 2004-23, §§ 1-2, 11-16-04)

Sec. 7-6-3. Basis for assigning numbers.

The numbering of buildings on such streets shall begin at the baseline. All buildings on the south side of east-west streets and east of north/south streets shall bear odd numbers and likewise all buildings on the north side of east-west streets and west of north/south streets shall bear even numbers.

A grid interval system shall be used with individual numbers being assigned according to lots. A six hundred- (600) foot interval shall be used to determine intervals with a twenty- (20) foot interval being used to change numbers.

- (A) A multiple-family dwelling, a mobile home or recreational vehicle park having only one (1) main street entrance shall be assigned only one (1) number, and separate units or spaces in the building or park will carry letter or number designations in addition to the number assigned to the main entrance of the building or park.
- (B) Any duplex houses having two (2) front entrances shall have a separate number for each entrance. If both entrances fall within the same increment, either the preceding number or the next higher number shall be used for one (1) entrance number, and the interval used for one (1) entrance number, and the interval number in which the entrances fall shall be used for the other entrance.

(Ord. No. 288, § 3, 5-3-88; Ord. No. 2004-23, §§ 1-2, 11-16-04)

Sec. 7-6-4. Buildings facing short streets.

All buildings facing streets not extending through to the baseline shall be assigned the same relative numbers as if the street had extended to the baseline.

(Ord. No. 288, § 4, 5-3-88; Ord. No. 2004-23, §§ 1-2, 11-16-04)

Sec. 7-6-5. Directional designation.

In addition to the numbers placed on each house or other building as heretofore provided, all streets, avenues and other public ways within the city are hereby given the following directional designation.

- (A) All streets north of McNeil Street and running in a generally northerly direction are given the direction of "north" as part of the street name.
- (B) All streets south of McNeil Street and running in a generally southerly direction are given the direction "south" as part of the street name.
- (C) All streets east of Central Avenue and running in a generally easterly direction are given the direction "east" as part of the street name.
- (D) All streets west of Central Avenue and running in a generally westerly direction are given the direction "west" as part of the street name.

(Ord. No. 288, § 5, 5-3-88; Ord. No. 2004-23, §§ 1-2, 11-16-04)

Sec. 7-6-6. Number assignment placement on buildings.

- (A) There shall be assigned to each house and building intended to be occupied by human beings its respective number under the uniform system provided for in this article. When each house or building has been assigned its respective number or numbers, the owner, occupant or agent shall place or cause to be placed upon each house or building controlled by him the number or numbers assigned under the uniform system as provided in this article.
- (B) Such numbers shall be placed on all appropriate existing buildings within thirty (30) days after the assignment of a permanent number. Per IBC 2006 Section 501.2, these numbers shall contrast with their background. Address numbers shall be Arabic numerals or alphabetical letters. Numbers shall be a minimum of four (4) inches (102 mm) high with a minimum stroke width of one-half (0.5) inch (12.7mm).
- (C) The number shall be conspicuously placed within one (1) foot of the front door to a building, if the front door is facing the street, avenue, or public way and is within forty (40) feet of the front property line. If the front door does not face the property, and the building is within forty (40) feet of the front property line, then the numbers shall be placed approximately six (6) feet above grade on the building nearest to the access way. Any building or house more than forty (40) feet from the roadway must place the address numbers on a placard or mailbox within five (5) feet of the entrance to the property.

(Ord. No. 288, § 6, 5-3-88; Ord. No. 2004-23, §§ 1-2, 11-16-04; Ord. No. 2008-15, § 1, 12-16-08)

Sec. 7-6-7. Plat book for the purpose of facilitating correct numbering.

A plat book of all streets, avenues and public ways within the city showing the proper number of all houses or other buildings fronting upon all streets, avenues or public ways shall be kept on file in the office of the city clerk. These plats shall be open to inspection by any person during the office hours of the city hall.

(Ord. No. 288, § 7, 5-3-88; Ord. No. 2004-23, §§ 1-2, 11-16-04)

Sec. 7-6-8. Duties of the building inspector.

It shall be the duty of the building inspector or his designee to inform any applicant of the number or numbers belonging to or embraced within the city limits of any such lot or property as provided in this article. In case of conflict as to the proper number to be assigned to any building, the planning and zoning director shall determine the number of such buildings. Final approval of any structure erected, repaired, altered or modified shall be withheld by the building inspector until permanent and proper numbers have been affixed to such structure.

(Ord. No. 288, § 8, 5-3-88; Ord. No. 2004-23, §§ 1-2, 11-16-04; Ord. No. 2008-15, § 1, 12-16-08)

Sec. 7-6-9. Approval required by new street names.

Everyone submitting a subdivision plat to the planning and zoning commission and to the city council for their approval shall show the proper names of any and all streets and these street designations shall be approved by the planning and zoning commission and by the city council before such new streets are officially named. Street name suggestions may originate with the parties submitting the plat under the guidance of the public works director.

(Ord. No. 288, § 9, 5-3-88; Ord. No. 2004-23, §§ 1-2, 11-16-04)

Sec. 7-6-10. Changing, renaming or naming existing streets.

The mayor and common council by resolution may change, rename or name an existing or newly established street within the limits of the City of Show Low at any time upon recommendation of the planning and zoning commission, the public works director, the city manager, or any other city council designee.

(Ord. No. 288, § 10, 5-3-88; Ord. No. 2004-23, §§ 1-2, 11-16-04)

ARTICLE 7-7. DEVELOPMENT FEES♣

♣**Editor's note**– Sections 1 and 2 of Ord. No. 2004-23, adopted Nov. 16, 2004, repealed and adopted, respectively, Chapter 7 in its entirety. Previously, Ord. No. 466, §§ 1 – 3, adopted June 20, 2000, with an effective date of October 1, 2000 added *Development Fees* as Art. 7-16; specifically, Art. 7-16-1 through 7-16-7. Also, *Police Facilities Development Fee*, formerly titled Section 7-16-14 was deleted entirely through Ord. No. 2003-14, adopted Sept. 2, 2003, which rescinded §§ 5 and 9 of Ord. No. 515, adopted July 2, 2002.

Editor's note– Sections 1 and 2 of Ord. No. 2011-13, adopted Dec. 6, 2011, amended section 7-7-2 and amended and renumbered sections 7-7-8 through 7-7-14, with an effective date of January 6, 2012. Specifically, Ord. No. 2011-13 deleted section 7-7-8, *Sewer Development Fee*; section 7-7-9, *Water System Development Fee*; section 7-7-12, *Open Space Development Fee*; and section 7-7-13, *Recreation Facilities Development Fee*. Sections 7-7-10, 7-7-11 and 7-7-14 were amended and renumbered to sections 7-7-8, 7-7-9, and 7-7-10, respectively. For further reference, see Res. No. R2011-45, adopted Dec. 6, 2011, in which water and wastewater capacity fees were implemented after sewer and water development fees were eliminated through Ord. No. 2011-13.

Editor's note– Sections 1, 2, and 3 of Ord. No. 2014-03, adopted June 17, 2014 and effective August 1, 2014, amended sections 7-7-2 through 7-7-5 and 7-7-8, eliminated section 7-7-9, *Park and Recreation Facilities Development Fee*, and renumbered section 7-7-10 to 7-7-9.

Sec. 7-7-1. Purpose and intent.

- (A) To establish uniform procedures for the imposition, calculation, collection, expenditure and administration of development fees imposed on new development;
- (B) To implement the goals, objectives and policies of the City of Show Low General Plan relating to assuring that new development contributes its fair share towards the costs of public facilities reasonably necessitated by such new development;
- (C) To ensure that new development is reasonably benefited by the provision of the public facilities provided with the proceeds of development fees;
- (D) To ensure that all applicable legal standards and criteria are properly incorporated in these procedures.

Sec. 7-7-2. Definitions.

- (A) *Development fee.* A fee adopted pursuant to applicable state law which is imposed on new development on a pro rata basis in connection with and as a condition of the issuance of a building permit and which is calculated to defray all or a portion of the costs of the public facilities required to accommodate new development at city-designated level of service (LOS) standards and which reasonably benefits the new development.
- (B) *Development fee committee.* A committee appointed by the mayor for the purpose of reviewing the city's development fees.
- (C) *Dwelling unit.* A room or group of rooms within a building containing cooking accommodations and designed to be used for living purposes. Dwelling unit shall not include or those units designed primarily for transient occupant purposes, nor shall they include rooms in hospitals, nursing homes, assisted living centers, or similar uses.
 - (1) *Single-family detached dwelling unit.* A dwelling unit designed and used only by one (1) family and which unit is physically separated from any other dwelling unit, including a manufactured home or manufactured home space or mobile home or mobile home space or a recreational vehicle located on a space or lot greater than 4,999 square feet.
 - (2) *Other dwelling unit.* A dwelling unit typically designed and used only for a single family, but which is either attached to another dwelling unit, such as an apartment, duplex, townhouse, or single-family attached dwelling unit.

This term shall also include additions to recreational vehicles as set forth below.

- (3) *Recreational vehicle dwelling unit.* A vehicle-type unit that is located on a space or lot less than 4,999 square feet and is less than four hundred (400) square feet gross floor area and is one of the following:
- (a) a travel trailer mounted on wheels, designed to provide temporary living quarters for recreational, camping, or travel;
 - (b) a park model built on a single chassis, mounted on wheels, designed to be connected to utilities necessary for operation of fixtures;
 - (c) a motor home or portable camping trailer designed to provide temporary living quarters. Any addition which increases the gross floor area above four hundred (400) square feet shall be considered an “other dwelling unit” as set forth above; or
 - (d) a recreational vehicle dwelling unit shall not include recreational vehicle (R.V.) parks in which spaces are rented or leased and are not individually owned. Such recreational vehicle parks shall pay water system and sewer system capacity fees based on commercial designations and not residential designations.
- (D) *Excluded library facility.* Library facilities for which development impact fees may not be charged pursuant to A.R.S. §9-463.05, including that portion of any library facility that exceeds ten thousand (10,000) square feet, and equipment, vehicles, or appurtenances associated with library operations.
- (E) *Library facilities.* A category of necessary public services in which literary, musical, artistic, or reference materials are kept (materials may be kept in any form of media such as electronic, magnetic, or paper) for noncommercial use by the public in a facility providing a direct benefit to development. Libraries do not include excluded library facilities, although a library may contain, provide access to, or otherwise support an excluded library facility.
- (F) *Multiple uses.* A new development consisting of both residential and non-residential uses, or one (1) or more different types of non-residential use, on the same site or part of the same new development.
- (G) *Necessary public services.* “Necessary public services” shall have the meaning prescribed in A.R.S. §9-463.05, subsection T, paragraph 5.
- (H) *New development.* Any new construction, reconstruction, redevelopment, rehabilitation, structural alteration, structural enlargement, structural extension,

or new use requiring any form of city building permit or approval; any change in use of an existing building, structure or lot requiring any form of city building permit or approval and which increases the demand for one or more public facilities or services, except as otherwise expressly provided herein.

- (l) *Street facilities (transportation).* A category of necessary public services including arterial or collector streets or roads, traffic signals, rights-of-way and improvements thereon, bridges, culverts, irrigation tiling, storm drains, and regional transportation facilities.

(Ord. No. 488, § 11, 6-5-01, Eff. 1-1-02; Ord. No. 495, § 1, 10-16-01; Ord. No. 2004-23, §§ 1-2, 11-16-04; Ord. No. 2007-16, §§ 1-2, 8-21-07, Eff. 11-20-07; Ord. No. 2011-13, §§ 1-3, 12-6-11, Eff. 1-6-12; Ord. 2014-03, §§ 1-3, 6-17-14, Eff. 8-1-14; Ord. No. 2017-02, §1, 1-17-17)

Sec. 7-7-3. General provisions; applicability.

- (A) Annual review.

- (1) At least once each year, the city manager or his designee shall coordinate the preparation and submission of an annual report to the city council on the subject of development fees in connection with the annual audit report or in such other manner as the city manager may determine.

- (2) The annual report may include any or all of the following:

- (a) Recommendations of the development fee committee;

- (b) Recommendations for amendments, if appropriate, to these procedures or to specific ordinances adopting development fees for particular public facilities;

- (c) Other data, analysis or recommendations as the city manager or appropriate designee may deem appropriate, or as may be requested by the city council.

- (B) Type of development affected. This article shall apply to all new development as herein defined and as defined in the development fee ordinances for particular public facilities.

- (C) Type of development not affected. This article shall not apply to:

- (1) No net increase in dwelling units. No development fee shall be imposed on any new residential development which does not add a new dwelling

unit, unless the new development increases the demand for public facilities for which development fees are being imposed.

- (2) No net increase in non-residential square footage. No development fee shall be imposed on any new non-residential development which does not add square footage, unless the new non-residential development increases the demand for public facilities for which development fees are being imposed.
 - (3) Other uses. No development fee shall be imposed on a use, development, project, structure, building, fence, sign or other activity, whether or not a building permit is required, which does not result in an increase in the demand for public facilities.
 - (4) Development projects which are the subject of a development agreement containing provisions in conflict with this article, but only to the extent of the conflict or inconsistency.
- (D) Effect of payment of development fees on other applicable city land use, zoning, platting, subdivision or development regulations.
- (1) The payment of development fees shall not entitle the applicant to a building permit unless all other applicable land use, zoning, planning, platting, subdivision or other related requirements, standards and conditions have been met. Such other requirements, standards and conditions are independent of the requirement for payment of a development fee.
 - (2) Neither this article nor the specific development fee ordinances for particular public facilities shall affect, in any manner, the permissible use of property, density/intensity of development, design and improvement standards or other applicable standards or requirements of the city land development regulations which shall be operative and remain in full force and effect without limitation.

(Ord. 2014-03, §§ 1-3, 6-17-14, Eff. 8-1-14)

Sec. 7-7-4. Procedures for imposition, calculation, and collection of development fees.

- (A) In general. An applicant shall be notified by the city of the applicable development fee requirements at the time of application for a building permit via the issuance of a development fee calculation form provided to the applicant. Development fees shall be calculated by the city and shall be paid by the applicant prior to the issuance of a building permit.

(B) Calculation.

- (1) Upon receipt of an application for a building permit, the city shall determine:
 - (a) Whether it is a residential or non-residential use,
 - (b) The specific category (type) of residential or non-residential development, if applicable,
 - (c) If residential, the number of new dwelling units.
- (2) Upon receipt of an application for a building permit, the city shall determine whether it is for a change in use. In such cases, the development fee due shall be based only on the incremental increase in the fee for the additional public facilities needed for the change in use.
- (3) After making these determinations, the city shall calculate the demand for the public facility added by the new development for each public facility category for which a development fee is being imposed and calculate the applicable development fee by multiplying the demand added by the new development by the amount of the applicable development fee per unit of development, incorporating any applicable offset if set forth in the particular development fee calculation methodology.
- (4) If the type of land use proposed for new development is not expressly listed in the particular development fee ordinance and schedule, the city shall:
 - (a) Identify the most similar land use type listed and calculate the development fee based on the development fee for that land use;
 - (b) Identify the broader land use category within which the specified land use would apply and calculate the development fee based on the development fee for that land use category.
- (5) An applicant may request a non-binding estimate of development fees due for a particular new development at any time by filing a request on a form provided for such purpose by the planning department, provided, however, that such estimate may be subject to change when a formal application for a building permit for a new development is made. Such non-binding estimate is solely for the benefit of the prospective applicant and shall in no way bind the city nor preclude it from making amendments or revisions to any provisions of this Article, the specific development fee implementing ordinances or the development fee schedules.

- (6) The calculation of development fees due from a multiple-use new development shall be based upon the aggregated demand for each public facility generated by each land use type in the new development.
- (7) Development fees shall be calculated based on the development fee amount in effect at the time of application for a building permit.

(C) Credits.

- (1) Credits against the amount of a development fee due from a new development shall be provided for, among other things, contributions made in cash, or by dedication of land or by actual construction of all or part of a public facility by the affected property owner for public facilities meeting or exceeding the demand generated by the new development and the contribution is determined by the city to be a reasonable substitute for the cost of public facilities which are included in the particular development fee calculation methodology.
- (2) No credits shall be allowed unless the city has approved in writing by the city council or the city manager the contribution or expenditure before it is made.
- (3) Credits for dedication of land or provision of public facilities shall be applicable only as to development fees imposed for the same types of public facilities which are proposed to be dedicated or provided. Even if the value of the dedication of land or provision of a public facility exceeds the development fee due for the type of public facility, the excess value may not be transferred to development fees calculated to be due from the applicant for other types of public facilities for which development fees may be imposed. Credits may, however, be transferred to the same applicant or to other applicants for new development which are proposed within the final approved platted area of the same development and for the same type of public facility.

(D) Collection.

- (1) The city shall collect all applicable development fees at the time of issuance of a building permit and shall issue a receipt to the applicant for such payment unless:
 - (a) The applicant is determined to be entitled to a full credit; or
 - (b) The applicant has been determined to be not subject to the payment of a development fee; or

- (c) The applicant has filed an appeal and a bond or other surety in the amount of the development fee, as calculated by the city and approved by the city attorney and city treasurer, has been posted with the city.
 - (d) The applicant executes a promissory note and deed of trust or other comparable security acceptable to the city for the balance due in accordance with such terms and conditions, including applicable administrative fees and title fees, as may be set forth in a resolution adopted by the city council.
- (2) Development fees shall be due at the time of issuance of a building permit even if development fees were paid by the applicant at an earlier time in the development permit or approval process if the amount of the development fees have increased since such prior approval. The applicant shall only be liable for the difference between the development fees paid earlier and those in effect at the time of issuance of the subsequent building permit.

(Ord. No. 2006-22, § 1, 8-15-06; Ord. 2014-03, §§ 1-3, 6-17-14, Eff. 8-1-14)

Sec. 7-7-5. Establishment of development fee accounts; appropriation of development funds; and refunds.

- (A) Development fee accounts. A development fee account shall be established by the city for each category of public facilities for which development fees are imposed. Such account shall clearly identify the category, account, or fund for which the development fee has been imposed. Sub-accounts may be established for individual development fee districts. All development fees collected by the city shall be deposited into the appropriate development fee account or sub-account, which shall be interest bearing. All interest earned on monies deposited to such account shall be credited to and shall be considered funds of the account. The funds of each such account shall be capable of being accounted for separately from all other city funds, over time. The city shall establish and implement necessary accounting controls to ensure that the development fee funds are properly deposited, accounted for and appropriated in accordance with this article, applicable state law and any other applicable legal requirements.
- (B) Refunds.
- (1) Expiration of building permit. An applicant who has paid a development fee for new development for which the necessary building permit has expired prior to construction shall be eligible to apply for a refund of development fees paid on a form provided by the city for such purposes.

Such application shall be made within sixty (60) days following expiration of the permit. No interest shall be paid by the city in calculating the amount of the refund.

- (2) A ten (10) percent administrative fee shall be deducted from the amount of any refund granted and shall be retained by the city in the appropriate development fee account to defray the administrative expenses associated with the processing of a refund application.
- (3) Refunds shall be made only to the current owner of property on which the new development was proposed.

(Ord. 2014-03, §§ 1-3, 6-17-14, Eff. 8-1-14)

Sec. 7-7-6. Appeals.

- (A) An appeal from any decision of a city official pursuant to this article shall be made to the city council by filing a written appeal with the city clerk within thirty (30) days following the decision which is being appealed; provided, however, that if the notice of appeal is accompanied by a cash bond or letter of credit in a form satisfactory to the city attorney and the city treasurer in an amount equal to the development fee calculated to be due, a building permit may be issued to the new development. The filing of an appeal shall not stay the imposition of the collection of the development fee as calculated by the city unless a cash bond or other sufficient surety has been provided.
- (B) The burden of proof shall be on the appellant to demonstrate that the decision of the city is erroneous.
- (C) All appeals shall detail the specific grounds therefore and all other relevant information and shall be filed on a form provided by the city for such purposes.

Sec. 7-7-7. Exemption/waivers.

- (A) Filing of application. Petitions for exemptions to the application of the provisions of this article or waivers from specific development fees shall be filed with the city council through the office of the city clerk on forms provided by the city.
- (B) Effect of grant of exemption/waiver. If the city council grants an exemption or waiver in whole or in part of development fees otherwise due, the amount of the development fees exempted or waived shall be provided by the city from non-development fee funds, as may be provided in the particular development fee ordinances establishing development fees for particular public facilities, and such funds shall be deposited to the appropriate development fee account within a

reasonable period of time consistent with the applicable city capital improvements program.

- (C) Development agreements. Nothing herein shall be deemed to limit the city's authority or ability to enter into development agreements pursuant to applicable state law with applicants for new development who may provide for dedication of land, payments in lieu of development fees, or actual infrastructure improvements. Such development agreements may allow offsets against development fees for contributions made or to be made in the future in cash, or by taxes or assessments or dedication of land or by actual construction of all or part of a public facility by the affected property owner.

Sec. 7-7-8. Library facilities development fee.

- (A) Until such time as the pledged debt for the construction of the library is satisfied, all new residential development in the City of Show Low shall be subject to the payment of a library development fee payable at the time of issuance of a building permit as follows:

<u>Residential Development</u>	<u>Per Dwelling Unit</u>
Single Family Detached	\$180
Other Dwelling Unit	\$143
Recreational Vehicle Dwelling Unit	\$134

(Ord. No. 469, § 1, 6-5-01, Eff. 10-1-01; Ord. No. 504, §§ 2-3, 11-20-01, Eff. 7-1-02; Ord. No. 515, § 1, 7-2-02, Eff. 10-1-02; Ord. No. 2003-20, § 1, 12-16-03, Eff. 4-1-04; Ord. No. 2004-23, §§ 1-2, 11-16-04; Ord. No. 2006-22, § 2, 8-15-06, Eff. 11-14-06; Ord. No. 2008-13, § 2, 10-7-08, Eff. 1-1-09; Ord. No. 2011-13, §§ 1-3, 12-6-11, Eff. 1-6-12; Ord. 2014-03, §§ 1-3, 6-17-14, Eff. 8-1-14)

Sec. 7-7-9. Streets facilities (transportation) development fee.

- (A) Until such time as the streets pledged debt is satisfied, all new development in the City of Show Low shall be subject to the payment of a transportation development fee payable at the time of issuance of a building permit as follows:

<u>Residential</u>	<u>Per Housing Unit</u>
Single-family Detached	\$1,112
All Other Housing Types	\$ 874
Recreational Vehicle Dwelling Unit	\$ 834

(Ord. No. 2007-16, § 3, 8-21-07, Eff. 11-20-07; Ord. No. 2008-13, § 2, 10-7-08, Eff. 1-1-09; Ord. No. 2011-03, § 1, 2-15-11; Ord. No. 2011-13, §§ 1-3, 12-6-11, Eff. 1-6-12; Ord. 2014-03, §§ 1-3, 6-17-14, Eff. 8-1-14)

ARTICLE 7-8. RECORDS AND PENALTY

Sec. 7-8-1. Retention.

The building official shall keep careful and comprehensive records of applications for permits, of permits issued, of inspections made, of reports rendered and of notices or orders issued. The building official shall provide state and county officials copies of building permits and certificates of occupancy as required by A.R.S. §9-467, as amended from time to time. He shall further retain on file copies of all papers in connection with building work for such time as may be required by law.

(Ord. No. 370, §§ 1-3, 2-1-94; Ord. No. 2004-23, §§ 1-2, 11-16-04)

Sec. 7-8-2. Penalty for violation of chapter.

Any person found guilty of violating any provision of this chapter shall be guilty of a civil violation punishable as provided in section 1-8-1(a) of this Code. Each day that a violation continues shall be a separate offense.

(Ord. No. 288, § 11, 5-3-88; Ord. No. 2004-16, § 1, 8-17-04; Ord. No. 2004-23, §§ 1-2, 11-16-04)

Sec. 7-8-3. Severability.

If any section, subsection, sentence, clause, phrase or portion of this code or any part of the adopted codes is for any reason held to be invalid or unconstitutional by the decision of any court of competent jurisdiction, such decision shall not affect the validity of the remaining portions thereof.

(Ord. No. 399, §§ 1-3, 7-16-96; Ord. No. 2004-23, §§ 1-2, 11-16-04)